

**INCLUDED IN
 PACKAGING:**

1 – Angle End Plate



2 – 17x3/4 Nails



3 – 8x1-1/2 Pan
 Head Screws



1 – 8x1/2 Flat Head
 Bumper Screw



WHAT YOU'LL NEED:



**Automatic Door Bottom
 Part # 330**

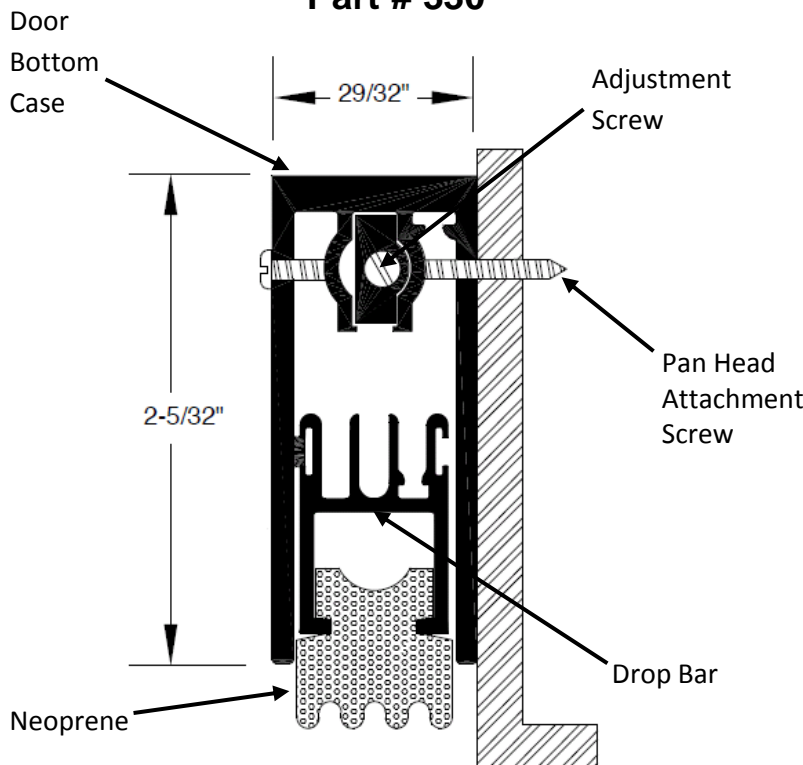

**Please Note - Maximum Cut Sizes:
 24\" cannot be trimmed.
 36\", 42\" and 48\" can be trimmed up to 3\"
 All other sizes can be trimmed up to 1\".**

Maximum Drop 3/4\"

ATTENTION: The 330 automatic door bottoms are not designed to seal directly on carpet. For best results, door bottoms should seal on a solid surface. The solid surface should be positioned above the level of the floor covering on either side of the door.

1. (OPTIONAL): Cut a MORTISE of 15/16\" wide and 2-3/32\" deep in the bottom of door. This allows 1/16\" clearance for the door bottom.

2. (OPTIONAL): Attach provided END PLATE on the lock side of the door and flush with the bottom of the door, leaving 3/16\" between the end plate and the door bottom. Use the nails provided and attach end plate with the small portion of the \"L\" pointed toward the door bottom. The long portion of the \"L\" should be tight to door stop.

3. Cut DOOR BOTTOM length to 3/16\" shorter than the distance between door stops or end plate (If using the semi-mortised application in Step 1, cut door bottom to 3/16\" shorter than width of the

door). Using a sharp saw, hold the door bottom drop bar flush with the end of the case and cut the same amount from the case and from the drop bar. This door bottom is designed to have the drop bar move sideways about 1/8" to 3/16" toward the swinging end of the door.

CAUTION: CUT ONLY THE END OF THE DOOR BOTTOM OPPOSITE OF THE ADJUSTMENT SCREW.

4. Mount DOOR BOTTOM using the 3 pan head screws, positioning the adjustment screw at the hinged side of the door and flush with the door stop when the door is closed. The door bottom should also be flush with bottom of the door. NOTE: Door bottom is reversible. Fits right and left-hand doors.

5. Loosen ADJUSTMENT SCREW until seal lightly hits floor evenly when the door is closed. Maximum drop 3/4". NOTE: The door bottom drops at the hinged end first so the swinging side of the door can swing freely.

6. (FOR WOOD FRAMES ONLY): Attach BUMPER SCREW to the door frame where the adjustment screw makes contact with the frame. This will ensure the door frame doesn't become indented where the adjustment screw hits.

7. Trim NEOPRENE insert if necessary. Extra neoprene at the hinged end of the bar can fill space.

8. Operate DOOR several times to ensure the gasketing material is properly adjusted so as not to inhibit the door from self-closing and latching.

WHAT TO WATCH FOR DURING INSTALLATION:

1. Make sure the drop bar is not pulled down too far when trimming or checking for burrs. Pulling the drop bar down too far can stretch the spring and may damage the operation of the door bottom.

2. When trimmed to length make sure there are no burrs or chips that have fallen into the case.

3. Case is not collapsed or pinched so drop bar can't come down. The drop bar must move freely. You should be able to have the bar go up and down with your finger.

4. Make sure the door is routed evenly at the size required (15/16"). The door bottom should not stick out further than the door.

5. Clearance under door is not greater than 3/4".

6. The automatic door bottom works on a pivot system. The adjustment screw hits the hinge side of the door frame making the drop bar come down on the hinge side - when the drop bar comes in contact with the floor, threshold or some hard surface it pivots the bar so that the latch or strike side of the drop bar will come down. Make sure the adjustment screw is adjusted correctly.



**Meets UL10B, UL10C Category J Meets CAN4-S104-2010
17L5 9903**

Positive Pressure Tested Gasketing Materials for Fire Doors. Intended for Application to/with listed steel frames and/or classified steel covered composite, hollow metal type fire doors rated up to 3 hours, wood and plastic covered composite type fire doors rated up to 1-1/2 hours, and wood core type fire doors rated up to 20 minutes.