

**INCLUDED IN
 PACKAGING:**

1 – Angle End Plate



2 – 17x3/4 Nails



3 – 6x1-1/4 Oval
 Head Screws



1 – 5/16" Block



**Automatic Door Bottom
 Part # 321**

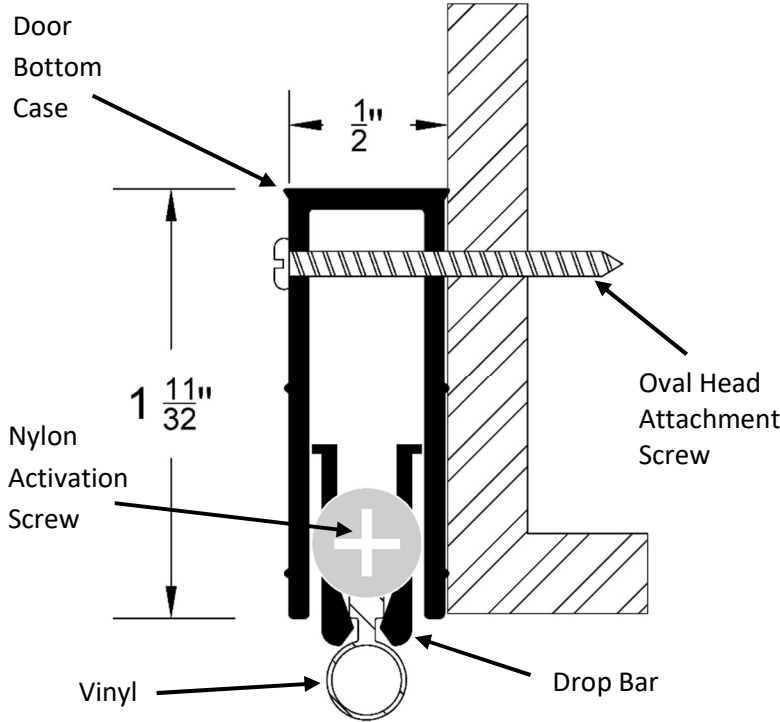

WHAT YOU'LL NEED:



**Please Note - Maximum Cut Sizes:
 12"-24" cannot be trimmed.
 36" and 48" can be trimmed up to 3"
 All other sizes can be trimmed up to 1".**

Maximum Drop 1/2"

ATTENTION: The 321 automatic door bottoms are not designed to seal directly on carpet. For best results, door bottoms should seal on a solid surface. The solid surface should be positioned above the level of the floor covering on either side of the door.

1. (OPTIONAL): Attach provided END PLATE on the lock side of the door and flush with the bottom of the door, leaving 1/8" between the end plate and the door bottom. Use the nails provided and attach end plate with the small portion of the "L" pointed toward the door bottom. The long portion of the "L" should be tight to door stop.

2. Cut DOOR BOTTOM length to 1/8" shorter than the distance between door stops or end plate. Using a sharp saw, hold the door bottom drop bar flush with the end of the case and cut the same amount from the case and from the drop bar. This door bottom is designed to have the drop bar move sideways 1/8" toward the swinging end of the door.

CAUTION: CUT ONLY THE END OF THE DOOR BOTTOM OPPOSITE OF THE ACTIVATION SCREW.

3. **Trim** VINYL insert if necessary. Extra vinyl at the hinged end of the bar can fill space.
4. **Mark** PILOT HOLES. With the door closed hold the activation screw tight against the door stop, on the hinged side, in the fully activated position. The door bottom case should be flush with the door stop on the hinged side. Position the door bottom so the vinyl is lightly touching the floor at all points, making sure there are no gaps in between the seal and the floor. Shim as needed to hold in position. Carefully mark the three-hole positions on the door.
5. **Remove** the 5/16" BLOCK that is holding the drop bar flush with the door bottom case. The drop bar will now be offset from the case.
6. **Mount** DOOR BOTTOM by first using a 5/64" drill bit to make pilot holes where there are markings. Using the 3 oval head screws, position the activation screw at the hinged side of the door. NOTE: Door bottom is reversible. Fits right and left-hand doors.
7. **Operate** DOOR several times to ensure the gasketing material is properly adjusted so as not to inhibit the door from self-closing and latching.

WHAT TO WATCH FOR DURING INSTALLATION:

1. When trimmed to length make sure there are no burrs or chips that have fallen into the case.
2. Case is not collapsed or pinched so the drop bar can't come down. The drop bar must move freely. You should be able to have the bar go up and down by pressing the activation screw with your finger.
3. Clearance under door is not greater than 1/2".



Meets UL10B, UL10C, and CAN4-S104-2010 Category J. 17L5 9903
Positive Pressure Tested Gasketing Materials for Fire Doors. Intended for Application to/with listed steel frames and/or classified steel covered composite, hollow metal type fire doors rated up to 3 hours, wood and plastic covered composite type fire doors rated up to 1-1/2 hours, and wood core type fire doors rated up to 20 minutes.